



New Brunswick™ Innova® 40/40R Shaker

Operating manual

Copyright

Copyright © 2014 Eppendorf AG, Germany. No part of this publication may be reproduced without the prior permission of the copyright owner.

The company reserves the right to change information in this document without notice. Updates to information in this document reflect our commitment to continuing product development and improvement.

Trademarks

Eppendorf® and the Eppendorf logo are registered trademarks of Eppendorf AG, Germany.

New Brunswick™ is a trademark of Eppendorf AG, Germany.

Innova® is a registered trademark of Eppendorf, Inc., USA.

BioCommand® is a registered trademark of Eppendorf, Inc., USA.

HyperTerminal® and Windows® are registered trademarks of Microsoft Corporation in the United States and other countries.

Phillips® is a registered trademark of Phillips Screw Company in the United States and other countries.

Allen® is a registered trademark of Allen Manufacturing Company, USA.

Sticky Pad® is a registered trademark of American Covers, Inc., USA.

Trademarks are not marked in all cases with ™ or ® in this manual.

Eppendorf has attempted to identify the ownership of all trademarks from public records. Any omissions or errors are unintentional.

Table of contents

1	Operating instructions	7
1.1	Using this manual	7
1.2	Danger symbols and danger levels	7
1.2.1	Hazard icons	7
1.2.2	Degrees of danger	7
1.3	Symbols used	8
1.4	Abbreviations used	8
2	Safety	11
2.1	User profile	11
2.2	Safety precautions	11
2.3	Warnings for intended use	11
3	Product description	13
3.1	Product overview	13
3.2	Delivery package	14
3.3	Features	14
3.4	Software interfaces	16
3.5	Drip pan reservoir	16
3.6	Heater	16
3.7	Alarms	16
3.8	Remote alarm (optional)	17
4	Installation	19
4.1	Selecting the location	19
4.2	Unpacking the device	19
4.3	Install the platform	20
4.4	Install flask clamp	22
4.5	Connecting to mains/power supply	24
5	Operation	25
5.1	Operating controls	25
5.2	Powering on	25
5.3	Operation	26
5.4	Changing screens	27
5.4.1	Screen names and descriptions	27
5.4.2	Choose screens	27
5.5	Opening the lid	28
5.6	Display Screen	28
5.6.1	Changing displayed parameters	29
5.6.2	Viewing the setpoints	29
5.6.3	Changing the setpoints	30
5.7	Summary screen	30
5.7.1	Changing setpoint values in the summary screen	31
5.8	Setup screen	31
5.8.1	Changing the day	32
5.8.2	Changing the time	32
5.8.3	To lock the settings	32

Table of contents

New Brunswick™ Innova® 40/40R Shaker
English (EN)

5.8.4	To mute the audible alarm	33
5.9	RS-232 screen	33
5.9.1	Changing the communication mode	33
5.9.2	Changing the baud rate	34
5.10	Calibrate screen	34
5.10.1	Temperature offset	35
5.10.2	Calculating the temperature offset	35
5.10.3	Creating the temperature offset	35
5.10.4	Calibrating the shaking speed	35
5.11	Programs screen	35
5.11.1	Create a program	36
5.11.2	Save the program	38
5.11.3	Edit a program	38
5.11.4	Run and stop a program	38
5.12	Program the timer	38
5.13	Power interruption	39
5.14	Remote programming	39
5.14.1	Connecting to a computer	39
5.14.2	Sending commands	40
5.14.3	Set Commands	41
5.14.4	Program control commands	41
5.14.5	Report request commands	43
5.14.6	Set/Get date and time commands	44
5.14.7	Index to command codes	45
6	Troubleshooting	47
6.1	Troubleshooting	47
7	Maintenance	49
7.1	Routine maintenance	49
7.2	Cleaning external and internal surfaces	49
7.3	Biohazard decontamination	49
8	Technical data	51
8.1	Specifications	51
8.1.1	Shaking	51
8.1.2	Temperature system	51
8.1.3	Power supply	51
8.1.4	Ambient conditions	52
8.1.5	Dimensions and weight	52
8.1.6	Alarms	52
8.1.7	Display	52
8.1.8	RS-232	52
8.1.9	ETL regulatory standards	53
8.1.10	CE regulatory standards	53
8.2	Certifications	53
9	Ordering information	55
9.1	Replacement parts	55
9.2	Accessories	55

9.2.1	Platforms	55
9.2.2	Replacement clamp hardware kits	56
9.2.3	Test tube racks and other accessories	56
10	Transport, storage and disposal	59
10.1	Disposal	59
	Index	60
	Certificates	63

Table of contents

New Brunswick™ Innova® 40/40R Shaker
English (EN)





1 Operating instructions

1.1 Using this manual

- ▶ Carefully read this operating manual before using the device for the first time.
- ▶ Also observe the operating manual enclosed with the accessories.
- ▶ The operating manual should be considered as part of the product and stored in a location that is easily accessible.
- ▶ When passing the device on to third parties, be sure to include this operating manual.
- ▶ If this manual is lost, please request another one. The current version can be found on our website www.eppendorf.com.

1.2 Danger symbols and danger levels

1.2.1 Hazard icons

	Electric shock		Crushing
	Material damage		Hazard point
	Heavy loads		

1.2.2 Degrees of danger



The following danger levels are used in safety messages throughout this manual.

DANGER	<i>Will</i> lead to severe injuries or death.
WARNING	<i>May</i> lead to severe injuries or death.
CAUTION	May lead to light to moderate injuries.
NOTICE	May lead to material damage.

Operating instructions

New Brunswick™ Innova® 40/40R Shaker
English (EN)

1.3 Symbols used

Example	Meaning
	You are requested to perform an action.
1. 2.	Perform these actions in the sequence described.
•	List.
	References useful information.

1.4 Abbreviations used

°C

Degree Celsius

cm

Centimeter

h

Hour

Hz

Hertz

kg

Kilogram

L

Liter

lb

Pound

in

Inch

min

Minute

mL

Milliliter

mm

Millimeter

rpm

Revolutions per Minute

S
Second

V
Volt

VA
Volt Ampere

Operating instructions

New Brunswick™ Innova® 40/40R Shaker
English (EN)

2 Safety

2.1 User profile

The device may only be operated by trained lab personnel who have carefully read the operating manual and are familiar with the device functions.

2.2 Safety precautions

Before operating the shaker, verify that anyone involved with its operation has been instructed in both general safety practices for laboratories and specific safety practices for this apparatus.

- The user is also responsible for following local guidelines for handling hazardous waste and biohazardous materials that may be generated from the use of this equipment.



WARNING! Risk of explosion and injury or death!

- ▶ Do not use equipment with flammable substances or organisms with flammable by-products.



NOTICE! Damage to device!

- ▶ Never run shaker without a platform.
-

2.3 Warnings for intended use



WARNING! Heavy!

- ▶ Do not attempt to lift the Innova 40/40R Shaker by yourself.
- ▶ Ask for assistance or use suitable equipment when raising or handling the device.



WARNING! Risk of electric shock and/or damage to unit!

- ▶ Check that the voltage and frequency of your unit are compatible with mains/power supply.
- ▶ Remove caution label from back of unit.
- ▶ Set the circuit breaker on the right side of the unit to the OFF position.



WARNING! Risk of electric shock and/or damage to device!

- ▶ Use a grounded power supply.

Safety

New Brunswick™ Innova® 40/40R Shaker
English (EN)

**WARNING! Risk of electric shock and/or damage to the device!**

- ▶ Before cleaning device, turn off and unplug from mains/power supply.

**WARNING! Risk of electric shock when replacing fuses!**

- ▶ Turn off shaker and disconnect from mains/power supply.

**WARNING! Risk of explosion and injury or death!**

- ▶ Do not use equipment with flammable substances or organisms with flammable by-products.

**WARNING! Injury from hazardous biological material!**

- ▶ Use respiratory protection when cleaning spills where aerosolization is suspected.
- ▶ Wear gloves, safety glasses, and laboratory coat when cleaning.

**NOTICE! Damage to device!**

- ▶ Never run shaker without a platform.

**CAUTION! Risk of injury and/or damage to unit**

- ▶ A minimum load is required to safely operate the Innova 40/40R Shaker.
 - ▶ Make sure the unit has a minimum load of 6.4 kg (14 lb) so that it can safely operate under the maximum speed (500 rpm). This includes the weight of the platform, flasks, and media.
-

3 Product description

3.1 Product overview

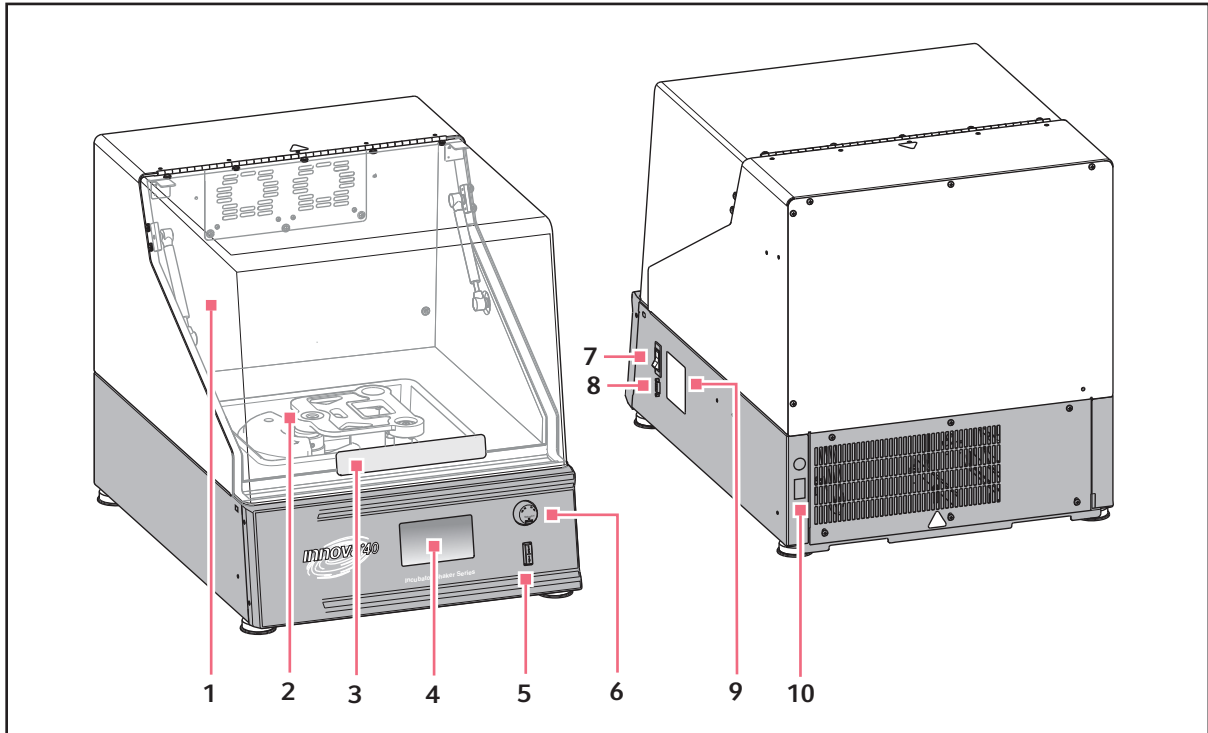

Fig. 3-1: Front and rear view of the New Brunswick Innova 40/40R Shaker

- | | |
|--|--|
| 1 Lid
With automatic stop function | 6 Control knob
Changes screens and selects operating conditions |
| 2 Drive
Triple eccentric drive - orbit is model-dependent | 7 Mains/Power switch
Switch device on or off (circuit breaker that turns power on and off to the entire device) |
| 3 Lid handle | 8 RS-232 interface
Read out parameter values and control operational functions using computer applications or also used to connect to BioCommand SFI |
| 4 Display
Graphical user interface with display of parameters and parameter values | 9 Name plate
Model number, documentation number, serial number and electrical connection data |
| 5 Start/Stop switch
Starts and stops shaking | 10 Mains/Power connection
Connect the power cable |

Product description

New Brunswick™ Innova® 40/40R Shaker
English (EN)

3.2 Delivery package

NOTE: Use of the Innova 40/40R Shaker requires a platform, which is a separate item (see *Platforms on p. 55*).

**WARNING! Shaker is very heavy!**

- ▶ Do not attempt to lift the Innova 40/40R Shaker by yourself.
- ▶ Always ask for assistance or use a lifter or other suitable equipment when raising or handling the unit.



- ▶ Check the delivery package for completeness.
- ▶ Check all parts for damage in transit.
- ▶ Retain the shipping box and packing material for subsequent storage or transport of the device.

3.3 Features

The Innova 40/40R Shaker is a benchtop orbital shaker that uses a triple eccentric counterbalanced drive mechanism.

Operation

The Innova 40/40R Shaker may be operated in the following ways:

- *Continuously:* at a set speed and temperature, until user stops device.
- *Timed mode:* run at a set speed, time, and temperature, after which the shaker automatically shuts off.
- *Shaker's programmable controller:* run through multiple temperature and speed changes for an extended period of time.
- *Computer through an RS-232 interface.*

Orbit

- Horizontal plane rotary motion.
- Available in 1.9 cm (3/4 in) or 2.5 cm (1 in) diameter circular orbit.

Refrigeration (Innova 40R only)

The refrigeration system in the Innova 40R is a variable-capacity system designed with self-checks to maintain the setpoint, to balance pressure within the system, and to keep the evaporator from freezing.

When the shaker is powered up, there is a 4 min time delay prior to compressor start-up.

Temperature control

Ambient temperature is measured at 1 m from the exterior of the unit.

- Innova 40R provides temperature control from 15 °C below ambient temperature to 80 °C with a minimum setpoint of 4 °C.
- Innova 40 provides temperature control from 5 °C above ambient temperature to 80 °C.

Both these ranges depend on relative humidity and other ambient factors, as well as the options installed on the device.

Safety

- Drive Interrupt shuts off power to shaker when lid opens.
- Acceleration/deceleration circuit prevents sudden starts and stops, minimizing both splashing and mechanical damage.
- Independent mechanical sensing switch also shuts the motor off in unbalanced condition.

Alarms

Innova 40/40R Shaker is equipped with visual and audible alarms that alert the user to the following conditions:

- The end of a timed run.
- Deviations from speed setpoint.
- Deviations from temperature setpoint.
- Mains/power failure.
- Lid is open.

Platforms

To accommodate customer needs, a wide variety of platforms can be used with the Innova 40/40R Shaker (see *Platforms on p. 55*):

- Universal platforms are the most flexible, providing hole patterns for flask clamps, test tube racks and other accessories.
- Dedicated platforms are supplied with 1 size flask clamps attached.

Flasks/Tubes

Erlenmeyer flasks (up to 3 L), and a wide variety of tubes and plates can be accommodated using the Eppendorf shaker accessories (see *Accessories on p. 55*).

Other accessories

Test tube racks, microplate holders, and test tube rack holders, as well as Sticky Pad® and sticky tape are also available (a universal platform is needed for all test tube racks and holders) (see *Accessories on p. 55*).

Product description

New Brunswick™ Innova® 40/40R Shaker
English (EN)

3.4 Software interfaces

The RS-232 port is located below the **Mains/Power switch** on the right side of the control panel. It can be used to connect a computer to the shaker for control of operating conditions or data logging applications (see *Remote programming on p. 39*).

The customer is responsible for securing the proper driver to interface with the RS-232.

3.5 Drip pan reservoir

The Innova 40/40R Shaker is equipped with a plastic liner to protect the electronics and temperature controls. An optional drip pan (M1250-9906) is recommended to protect the drive mechanism in case of accidental spills and/or broken glassware.

3.6 Heater

When the heater is on, the heater on icon appears in the display . The heater automatically stops running when the lid is opened.

The heater has the following features:

- 1000 ohm platinum RTD.
- Pulse width modulation on a 2.5 s duty cycle (this cycle time is fast enough to prevent noticeable changes in air temperature).
- Long-life, low-watt density resistance-type heater with high temperature thermostat.

3.7 Alarms

If an alarm condition exists, the field in the lower right corner alternates the day and time with characters indicating the nature of the alarm condition, accompanied by an audible alarm (unless muted) (see *Setup screen on p. 31*).

Tab. 3-1: Alarm descriptions

Indication	Description
TEMP	<ul style="list-style-type: none"> • Indicates that the temperature has deviated more than ± 1 °C from setpoint after achieving control temperature range. • After door is opened, alarm is disabled for 5 min while chamber recovers to setpoint.
RPM	<ul style="list-style-type: none"> • Indicates that the speed has deviated more than ± 5 rpm from setpoint after achieving operating speed setpoint. • After door is opened, alarm is disabled for 5 min while chamber recovers to setpoint.
POWER	<ul style="list-style-type: none"> • Indicates that the unit is powering up (both at normal power-up and after power interruption); flashes until the control knob is moved.
HRS	<ul style="list-style-type: none"> • Indicates when timed run is completed.

3.8 Remote alarm (optional)

The Innova 40/40R Shaker can be equipped with a factory-installed remote alarm component (M1320-8029). When it is hooked up to your relay and receiving equipment, this device sends notification of an alarm condition to the remote location you choose.

Product description

New Brunswick™ Innova® 40/40R Shaker
English (EN)

4 Installation

4.1 Selecting the location



WARNING! Heavy!

- ▶ Do not attempt to lift the Innova 40/40R Shaker by yourself.
- ▶ Ask for assistance or use suitable equipment when raising or handling the device.

Select the location for the device according to the following criteria:

- Suitable power connection.
- Access to RS-232 port.
- Surface where you place the device must be smooth and sturdy.
- Ambient temp of 10 °C – 35 °C.
- Relative humidity of 20 % – 80 %.
- Surrounding area must be well ventilated.
- Allow 7.6 cm (3 in) around shaker for ventilation.
- Up to 2000 m.
- Able to accommodate 90.8 kg (200 lb).

Ensure there is at least this much space for the Innova 40/40R Shaker:

Space requirements	Width: 68.6 cm (27 in) Depth: 83.2 cm (33 in) Height: 106.7 cm (42 in)
--------------------	--



Ensure there is enough room to disconnect the shaker from mains/power in case of emergency.

4.2 Unpacking the device



Keep the packing material and transport securing device for later transport or storage.

1. Remove the packing material.
2. Remove the transport securing device.
3. Use the details included in the scope of delivery to check that the delivery is complete.
4. Check all parts for damage in transit. Contact Eppendorf Service if parts are missing or transport damage is present.



Before placing the shaker on the bench, be sure to remove the four red plastic feet protectors.

Installation

New Brunswick™ Innova® 40/40R Shaker
English (EN)

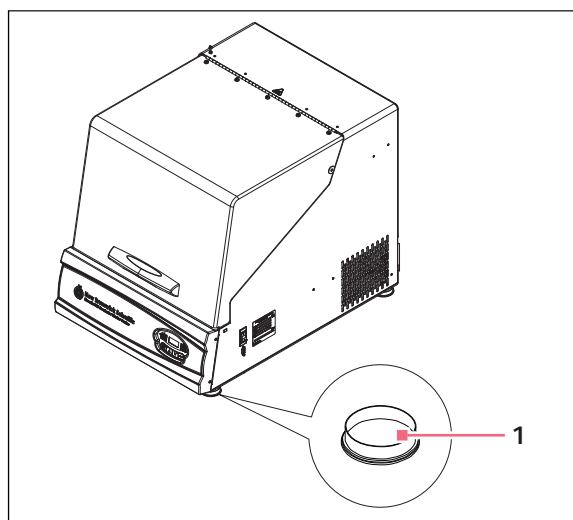
**1 Plastic foot protector**

During unpacking, remove protectors from each of the four feet on the Innova 40/40R Shaker

4.3 Install the platform



A platform with typical anticipated clamps and load must be installed prior to use.

The Innova 40/40R Shaker can be used with a variety of Eppendorf platforms that accept a wide range of clamps for flasks, test tubes, etc. A platform, which is required for operation, is a separate item, not included with the shaker assembly (see *Platforms on p. 55*).

**NOTICE! Damage to device!**

- ▶ Never run shaker without a platform.

Tools required (provided):

- Allen® key, 4 mm (5/32 in)

A platform must be installed on the device prior to use. To install:

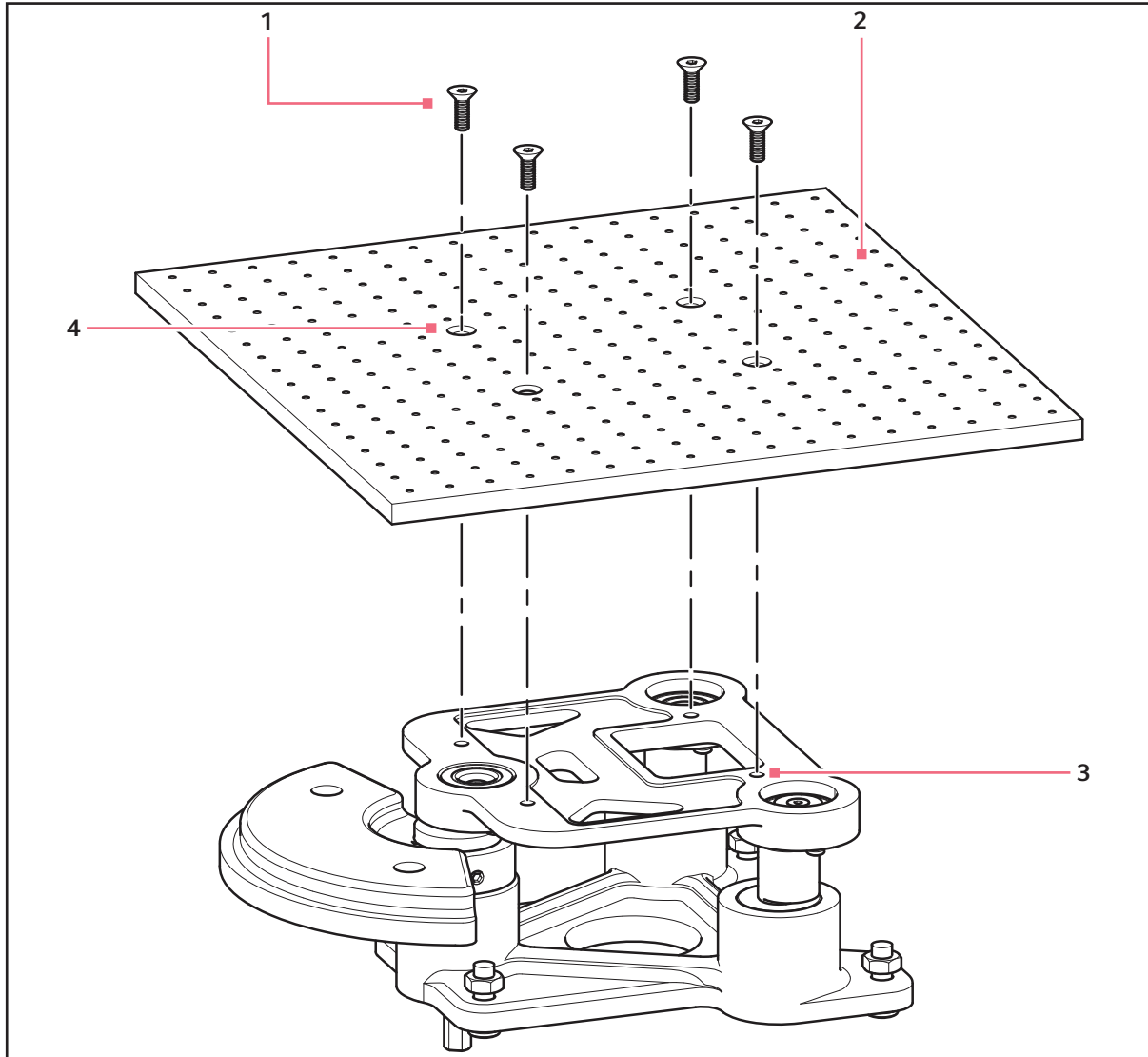

Fig. 4-1: Platform installation

- | | |
|----------------|-----------------------|
| 1 Allen screws | 3 Platform holes |
| 2 Platform | 4 Housing plate holes |

1. Set the **Mains/Power switch** off.
2. Open the lid.
3. With the Allen key provided, loosen and remove the 4 Allen screws installed on the top plate of the bearing housing (set screws aside for reuse).

Installation

New Brunswick™ Innova® 40/40R Shaker
English (EN)

4. Place the platform on top of the plate of the bearing housing and align the holes.
5. Reinstall and secure the 4 screws.

4.4 Install flask clamp

**NOTICE!**

- ▶ Do not overfill flasks.
-



Eppendorf flask clamps are used on a variety of shaker platforms. Flat head screws of different lengths and thread pitch are used to secure the clamp.

Materials needed:

- Phillips® screwdriver
- 10 – 24 × 5/16 in (7.9 mm) flat Phillips screws

Flask clamps purchased for use with universal platforms require installation (see *Accessories on p. 55*). Clamps are installed by securing the base of the clamp to the platform with the correct type and number of screws. All clamps are shipped complete with hardware.

Clamps for 2 L and 2.8 L flasks are shipped with an additional girdle to keep the flasks in place. The girdle is an assembly of springs and sections of rubber tubing. One girdle is already in place on the clamp, the other is packed separately.

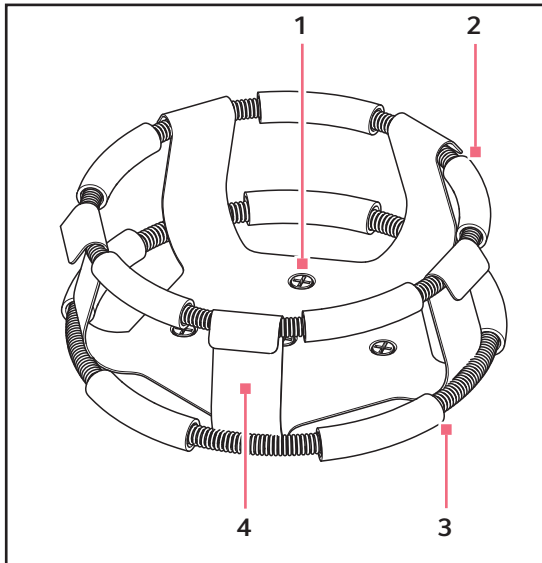

Fig. 4-2: Double girdle clamp

- | | |
|--|---|
| <p>1 Clamp mounting holes (with screws)</p> <p>2 Upper girdle with girdle tubes
 Secures the flask within the clamp.</p> | <p>3 Lower girdle with girdle tubes
 Prevents the flask from spinning</p> <p>4 Clamp body (legs and base)</p> |
|--|---|

To install these double girdle clamps:

1. Place the clamp on the platform, aligning its mounting holes with the holes on the platform.
2. Secure the clamp in place using the Phillips screwdriver and screws provided.
3. With the first girdle in place, as delivered, on the upper part of the clamp body, insert an empty flask into the clamp.
4. After making sure the sections of tubing are located between the clamp legs, roll the first girdle down the legs of the clamp as far as it can go.
 The tubing sections rest against the platform, and the springs are under the clamp base.
5. Place the second girdle around the upper portion of clamp body (just as the first girdle was initially).
6. Make sure that its spring sections rest against the clamp legs, while its rubber tubing sections sit against the flask, in between the clamp legs.



• 1 L and larger flask clamps are fastened with 5 screws.

Description	Part No.	Quantity	Application
 10 – 24 × 5/16 in (7.9 mm)	S2116-3051	1	5/16 in (7.9 mm) thick aluminum, phenolic, and stainless steel platforms.

Installation

New Brunswick™ Innova® 40/40R Shaker
English (EN)

4.5 Connecting to mains/power supply

Please read the following warnings!

**WARNING! Risk of electric shock and/or damage to unit!**

- ▶ Check that the voltage and frequency of your unit are compatible with mains/power supply.
- ▶ Remove caution label from back of unit.
- ▶ Set the circuit breaker on the right side of the unit to the OFF position.

**WARNING! Risk of electric shock and/or damage to device!**

- ▶ Use a grounded power supply.

**CAUTION! Risk of injury and/or damage to unit**

- ▶ A minimum load is required to safely operate the Innova 40/40R Shaker.
- ▶ Make sure the unit has a minimum load of 6.4 kg (14 lb) so that it can safely operate under the maximum speed (500 rpm). This includes the weight of the platform, flasks, and media.

-
- ▶ Only after taking the preceding precautions, plug the power cord into the mains/power supply.

5 Operation

5.1 Operating controls

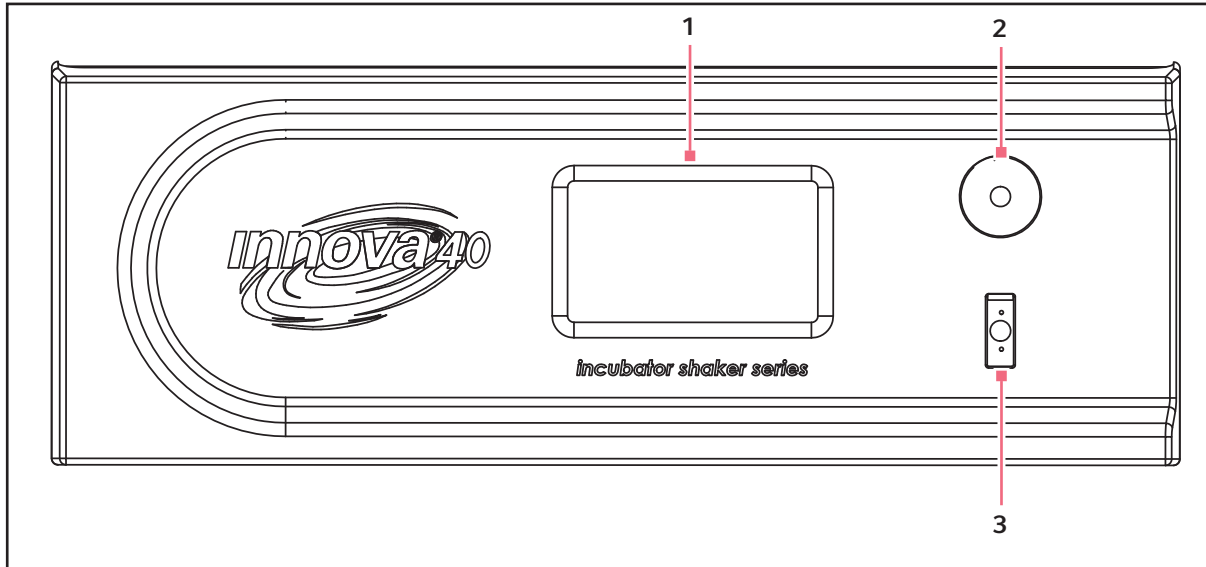

Fig. 5-1: Front panel of Innova 40/40R Shaker

1 Display

LCD

2 Control knob

Used to change screens and select operating conditions

3 Start/Stop switch

Stops or starts shaker agitation

Activates timer when using a timed run

5.2 Powering on

1. Close the lid.

2. Turn **Mains/Power switch** to the **On** position.

The display comes on (briefly displaying product information), and then moves into the *DISP* screen. An audible alarm sounds.

3. Turn the **Control knob** to turn alarm off. The audible alarm can be muted (see *Setup screen* on p. 31).

When the shaker begins to operate, the display tracks the speed as it accelerates to the last entered setpoint. The shaking action can be started or stopped by pressing the **Start/Stop switch** on the front panel.



The shaker does not operate if the lid is open. This is indicated by the lid open icon appearing in the bottom line of the display (see Fig. 5-2 on p. 26).

Operation

New Brunswick™ Innova® 40/40R Shaker
English (EN)

5.3 Operation

When the unit is powered up using the **Start/Stop switch** located on the front panel (see Fig. 5-1 on p. 25), the initial display screen remains on for a short time while the system boots up.

Then the main screen, called *DISP* for Display, appears. This screen indicates the same parameters that were in effect when the power was turned off.

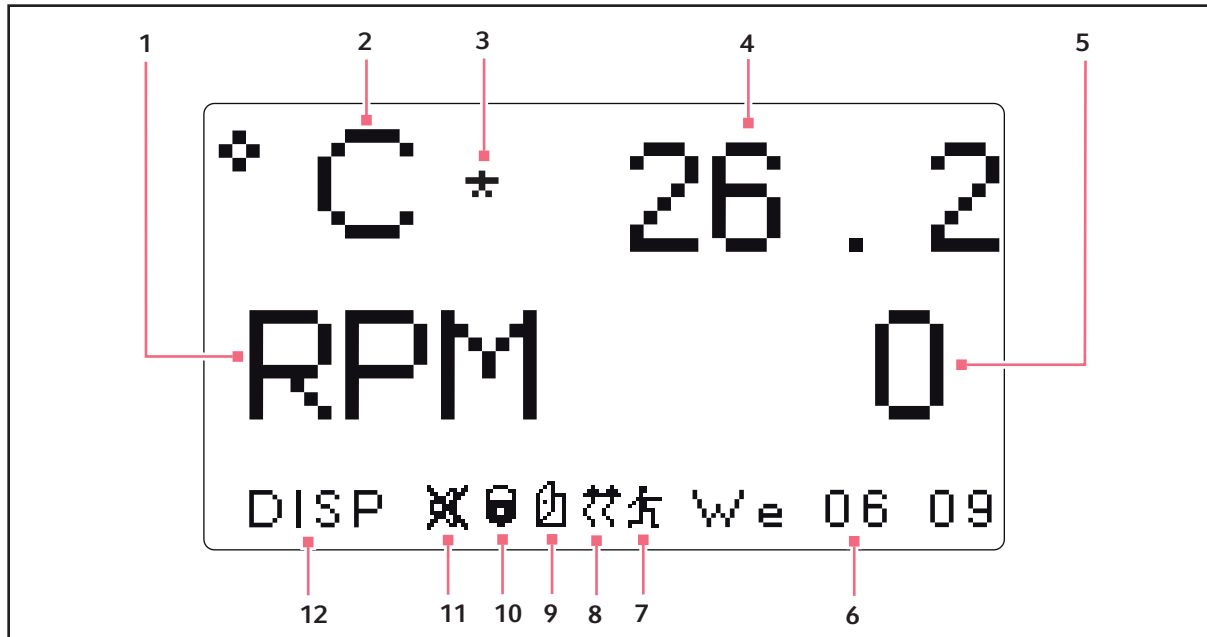

Fig. 5-2: Display screen

1 Speed

Parameters in rpm (revolutions per minute).

2 Temperature

Parameters in degrees Celsius.

3 Temperature offset

This icon appears to the right of °C if the Temperature Offset feature is being used.

4 Temperature

Temperature parameter value

5 Speed

Speed parameter value

6 Day & 24-hour time

7 Program running

Icon appears when user-defined program is running.

8 Heater on

Icon appears when heater is on

9 Lid open

Icon appears when lid is open

10 Parameters locked

This icon appears when the possibility to make manual or programmed parameter changes is disabled (locked). This is controlled by settings on the *SET* screen.

11 Audible alarms muted

Icon appears when audible alarms are muted

12 Screen name

Parameter name and meanings:

Parameter name	Meaning
RPM	Shaking speed, in revolutions per minute.
°C	Chamber temperature, in degrees Celsius.
HRS	Programmed time remaining, in hours.

5.4 Changing screens

5.4.1 Screen names and descriptions

There are 6 screens on the display:

Tab. 5-1: Screen names and descriptions

Screen name (displayed in bottom-left corner)	Meaning	Description
<i>DISP</i>	Display	Displays 2 user-selectable parameters and measured values. Changes setpoint values (see <i>Display Screen on p. 28</i>).
<i>SUMM</i>	Summary	Displays all parameters, measured values, and setpoints. Changes all parameters, measured values, and setpoints (see <i>Summary screen on p. 30</i>).
<i>SET</i>	Set	Sets the day of the week, set time, enable or mute alarm, lock, or unlock operating parameters (see <i>Setup screen on p. 31</i>).
<i>COMM</i>	Communication	Sets the communication mode and baud rate (see <i>RS-232 screen on p. 33</i>).
<i>CAL</i>	Calibration	Allows user to enter a temperature offset. Allows user to calibrate speed (see <i>Calibrate screen on p. 34</i>).
<i>PROG</i>	Program	Allows user to set up 1 – 4 programs, each with 1 – 15 steps (see <i>Programs screen on p. 35</i>).

5.4.2 Choose screens

The following example shows changing from the *DISP* (display) screen to the *SET* (setup) screen:

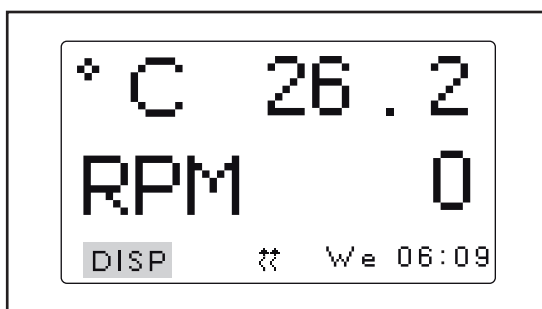

1. Turn the **Control knob** to highlight *DISP* in the bottom-left corner of the screen.
2. Press the **Control knob** until it clicks. *DISP* flashes.

Operation

New Brunswick™ Innova® 40/40R Shaker
English (EN)

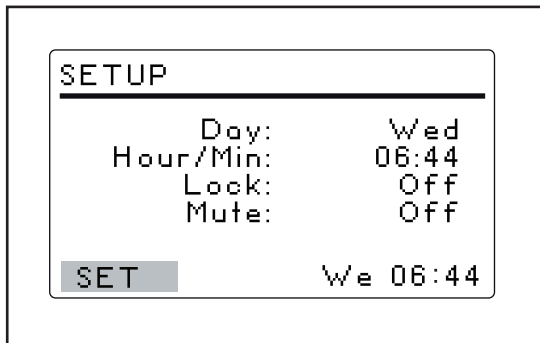

3. Turn the **Control knob** to choose the *SET* screen.
4. Press the **Control knob** until it clicks to save your selection.

You changed from the *DISP* screen to the *SET* screen.

Repeat the procedure to select any screen.

5.5 Opening the lid

- ▶ Open the lid by grasping the handle and lifting up.
- ▶ When you close the lid, make sure that it closes tightly (shaker does operate until lid is closed all the way).

5.6 Display Screen

The *DISP* screen displays 2 parameters and the measured values. Use this screen to:

- Change displayed parameters.
- View measured values.
- View and change setpoints.

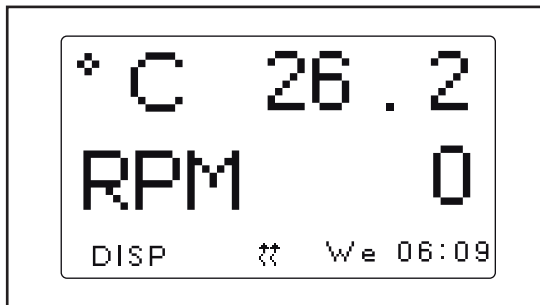
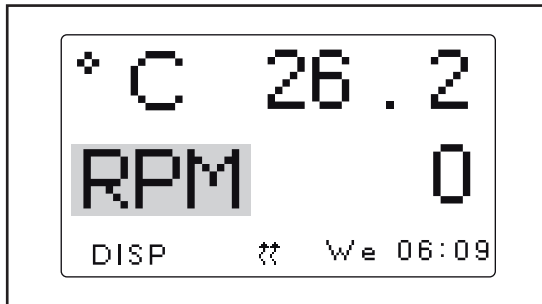
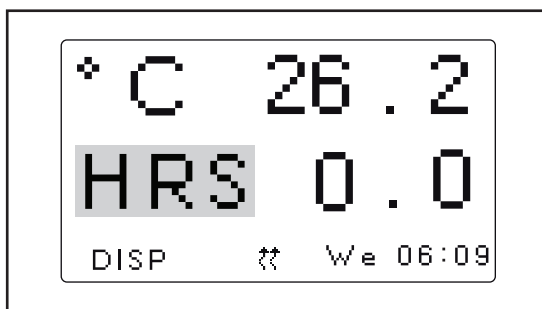

Fig. 5-3: Display screen

5.6.1 Changing displayed parameters



1. Turn **Control knob** to highlight the parameter you wish to replace. This example shows changing the parameter from *RPM* to *HRS*.
2. Press the **Control knob** until it clicks. *RPM* flashes.



3. Turn the **Control knob** until the desired parameter appears in the highlighted field.
4. Press the **Control knob** to save the parameter.



- If you do not press the **Control knob** to save your selection, after a few seconds the screen reverts to its previous settings.

5.6.2 Viewing the setpoints

You can verify the setpoints in the *DISP* screen. The parameter values displayed are the measured values. The setpoint values are user-selected. They may differ depending on many variables.

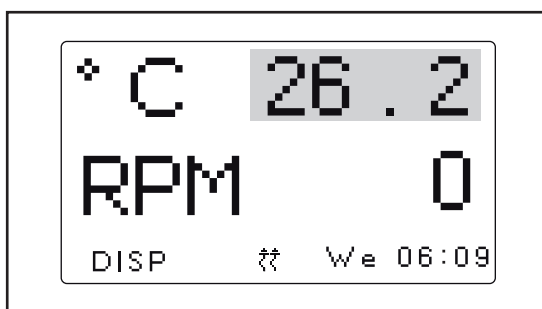

1. Turn the **Control knob** to highlight the actual (measured) parameter value.
2. Press the **Control knob** to display the setpoint. The setpoint flashes.
3. Click **Control knob** in again to return to normal display.

Operation

New Brunswick™ Innova® 40/40R Shaker
English (EN)

5.6.3 Changing the setpoints

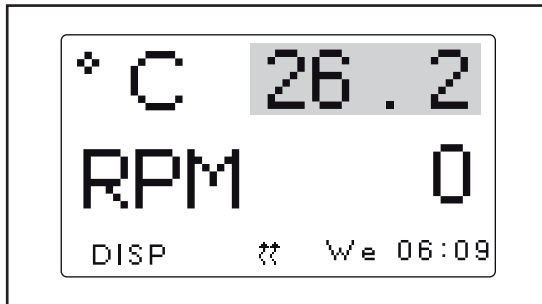

1. Use the **Control knob** to highlight the measured (actual) value (26.2 °C in figure).
2. Press the **Control knob**.
The setpoint flashes.



3. Turn the **Control knob** to change the setpoint to desired value (20.2 °C in figure).
The **Control knob** changes by increments of (0.1 °C). If you spin the **Control Knob** fast, the value changes by larger increments.
4. Click the **Control knob** in to save the new setpoint.
The display automatically returns to the measured actual value.



- If you highlight an item, change it, but do not save your selection, after a few seconds the screen reverts to its previous setting.

5.7 Summary screen

In the *SUMM* (summary) you can see both the, *ACTUAL* (measured) values and the *SET* (user-selected setpoint values).



- *ACTUAL* values are the current measured values in the shaker. You cannot change the values on the screen.
- *SET* values are the values the user selects.

PARAM	ACTUAL	SET
RPM	Off	0
°C	37.1	37.0
HRS	0.0	0.0
SUMM		We 06:44

Fig. 5-4: Summary screen

5.7.1 Changing setpoint values in the summary screen

Like in the *DISP* screen, you can change the setpoints in the *SUMM* screen:

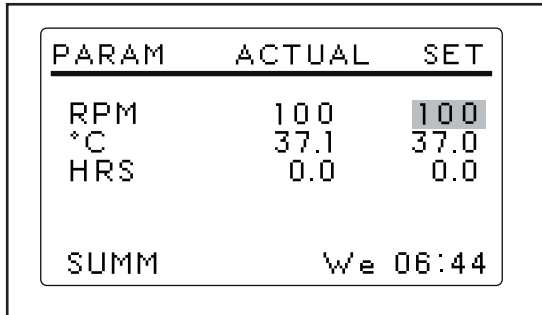

1. Turn the **Control knob** to select the desired setpoint. This example highlights *100* to change the *RPM* setpoint.
2. Click the **Control knob** in. Setpoint value flashes.

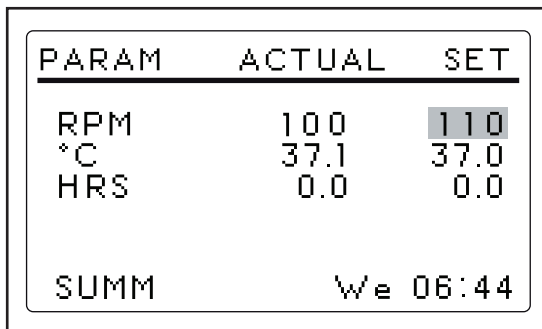

3. Turn the **Control knob** clockwise to increase the value or turn counter-clockwise to decrease the value. This example shows changing the setpoint from *100* to *110*.
Click the Control knob in to save the new setpoint value.
4. Repeat the procedure to change the other setpoint values.



- If you turn the **Control knob** but did not save the setpoint value, after a few seconds the screen reverts to its previous settings.

5.8 Setup screen

In the *SET* (setup) screen you can set the day of the week and the time (on a 24 h clock). This screen also allows you to lock all of your settings from further changes, and to mute or enable the audible alarm.

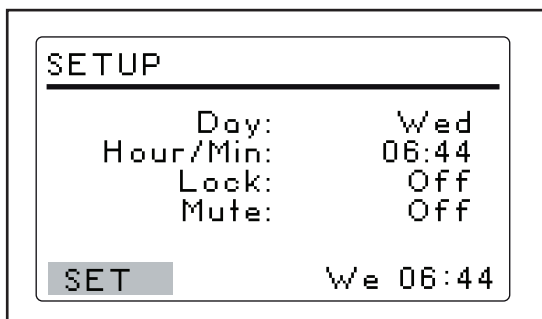

Fig. 5-5: Setup screen

Operation

New Brunswick™ Innova® 40/40R Shaker
English (EN)

5.8.1 Changing the day

In the *SET* screen:

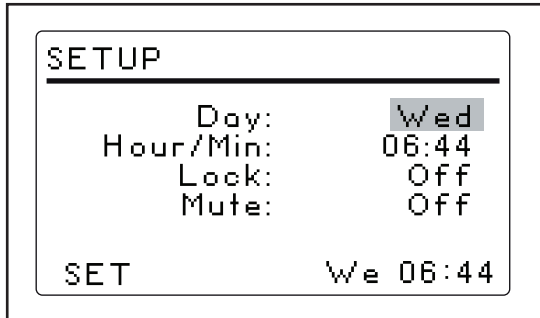

1. Turn the **Control knob** to highlight the day (*Wed* in figure).
2. Press the **Control knob**.
The day flashes.
3. Turn the **Control knob** to select a different day.
4. Press the **Control knob** to save your selection.



- If you do not press the **Control knob** to save your choice, after a few seconds the screen reverts to its previous settings.

5.8.2 Changing the time

In the *SET* screen:

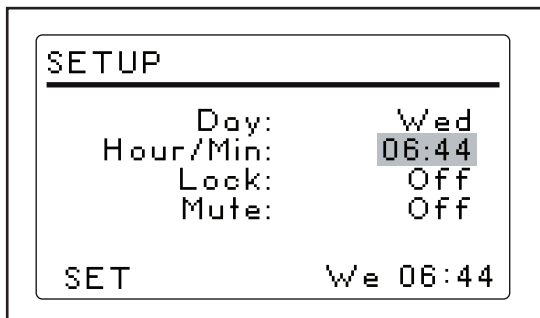

1. Turn the **Control knob** to highlight the time.
2. Press the **Control knob**.
The time (*06:44*) flashes.
3. Turn the **Control knob** clockwise or counterclockwise to select a different time. Clockwise moves the time forward, counterclockwise moves the time back. One click clockwise or counterclockwise moves the time in 1 min increments. Turning the **Control knob** faster changes the time more rapidly.
4. Press the **Control knob** to save your selection.

5.8.3 To lock the settings

In the *SET* screen:

1. Turn the **Control knob** to highlight the *Lock* status.
2. Press the **Control knob**.
The current status of the *Lock* (*On* or *Off*) flashes.
3. Turn the **Control knob** to select *On* or *Off*.
4. Press the **Control knob** to make a selection.

When you select *On*, the Lock icon appears at the bottom of the screen. This icon remains on display on all screens until you turn the Lock function *Off*.

5.8.4 To mute the audible alarm

In the *SET* screen:

1. Turn the **Control knob** to highlight the *Mute* status (*On* or *Off*).
2. Press the **Control knob**.
The current status of the alarm (*On* or *Off*) flashes.
3. Turn the **Control knob** to select *On* or *Off*.
4. Press the **Control knob** to save your selection.
When you set *Mute* to *On*, the mute icon appears at the bottom of the screen. This icon is displayed on all screens until you turn *Mute* to *Off*.

5.9 RS-232 screen

This *COMM* screen (communication) is used if you have connected a PC to the RS-232 port. Software such as New Brunswick™ BioCommand® allows you to record and log data from your shaker. Use the RS-232 screen to:

- Select the RS-232 port *Mode*.
- Select the *Baud Rate* appropriate to your PC.

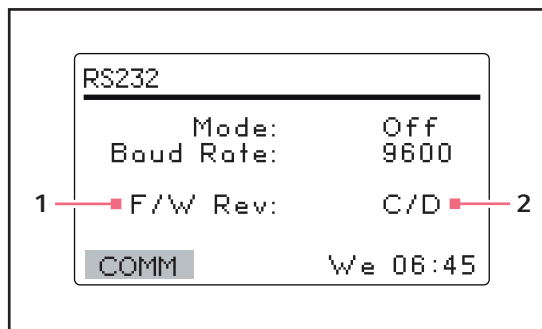

Fig. 5-6: Communication screen

- 1 **FirmWare Revision (this line is for information only).**
- 2 **In this sample screen, the Display is at Revision C and the FirmWare Control Board at Revision D.**

5.9.1 Changing the communication mode

In the *RS232* screen:

1. Turn the **Control knob** to highlight the *Mode* status.
2. Press the **Control knob**.
The current setting flashes.

Operation

New Brunswick™ Innova® 40/40R Shaker
English (EN)

3. Turn the **Control knob** to select make your selection.
4. Press the **Control knob** to save your setting.

Tab. 5-2: Communication mode

Mode	Application
<i>Off</i>	The RS-232 port is not open to communication in either direction.
<i>Slave</i>	The shaker can be fully controlled from the computer.
<i>Talk</i>	The shaker sends current value reports to the computer once per minute.
<i>Monit</i> (Monitor)	The shaker responds only to "Report Requests".

5.9.2 Changing the baud rate

In the *RS232* screen:

1. Turn the **Control knob** to highlight the current setting.
The settings are: *9600*, *19200*, and *38400*.
2. Press the **Control knob**.
The current setting flashes.
3. Press the **Control knob** to save your selection.

5.10 Calibrate screen

Use the *CAL* (calibrate) screen to:

- Create a temperature offset.
- Calibrate shaking speed.

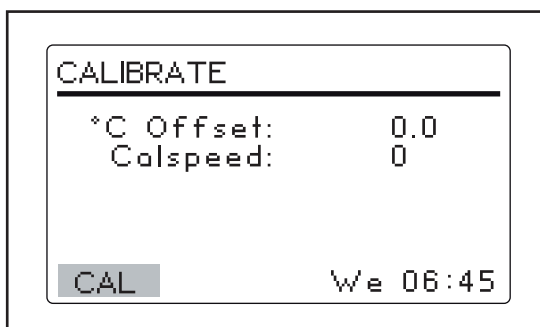

Fig. 5-7: Calibrate screen

5.10.1 Temperature offset

There is a temperature offset function on the Innova 40/40R Shaker that allow you to match a reference point temperature inside the chamber with the actual value displayed. The actual value displayed may not equal the temperature at different points of the shaker chamber due to many variables.

If you wish to have the actual value displayed on the shaker match a different point of the chamber, you must:

1. Calculate the temperature offset desired.
Create the temperature offset in the *CAL* screen.

5.10.2 Calculating the temperature offset

In the *CAL* screen:

1. Allow the shaker enough time to equilibrate to setpoint temperature.
2. Record the displayed setpoint temperature (**temp1**).
3. Record the temperature inside the chamber (**temp2**). You may record the temperature inside a flask or at any point inside the temperature.
4. Use the formula: **temp2 - temp1 = °C offset**

5.10.3 Creating the temperature offset

In the *CAL* screen:

1. Calculate the temperature offset value to plug in
(see *Calculating the temperature offset on p. 35*).
2. Turn the *Control knob* to select the °C *Offset* value
(0.0 in figure).
3. Enter the °C *offset* desired.

5.10.4 Calibrating the shaking speed

The Innova 40/40R Shaker is calibrated at the factory. The speed does not need to be recalibrated until a major operating component (e.g. a drive belt) is changed. This should be done by a qualified service technician.

5.11 Programs screen

Use the *PROG* screen to program steps for the shaker. The resident software for the Innova 40/40R Shaker can store up to four programs, each having as many as 15 steps. Each step can be programmed in 1 min increments, for total periods of 0 hr 1 min – 99 hr 59 min.

To enter the programming mode, use the **Control knob** to select the *PROG* screen.

Operation

New Brunswick™ Innova® 40/40R Shaker
English (EN)

In the *PROG* screen you can:

- *Run* a program.
- Create a *New* program.
- *Edit* a program.
- Turn *Off* a program.

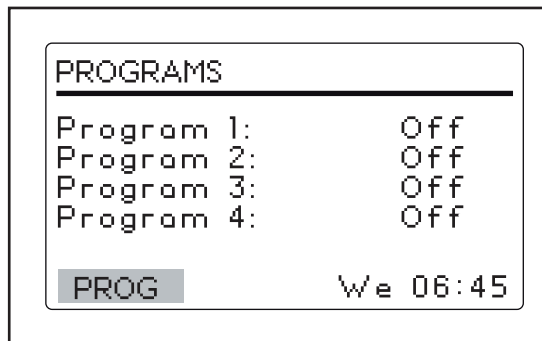
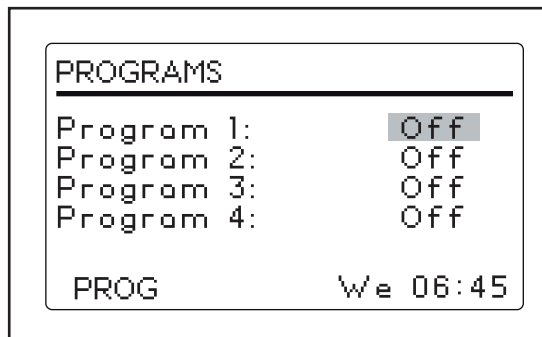

Fig. 5-8: Program screen

5.11.1 Create a program

To write a new multi-step program in the *PROG* screen:



1. Use the **Control knob** to highlight the mode of *Program 1* (*Off* in figure).
2. Press the **Control knob**.
The selected field flashes.

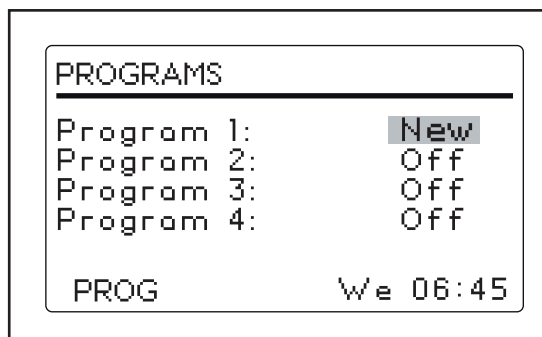

3. Turn the **Control knob** until the field says *New*.
4. Press the **Control knob** to select *New*.
The screen changes and you can start programming Step 1.

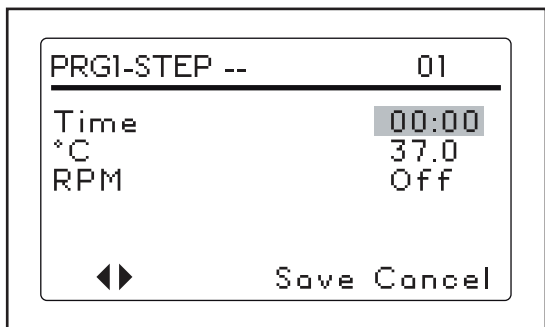

5. Turn the **Control knob** to highlight the *Time* value.
6. Press the **Control knob**.
The time flashes.
7. Turn the **Control knob** until the desired running duration for this step (from *00:01* – *99:59*)

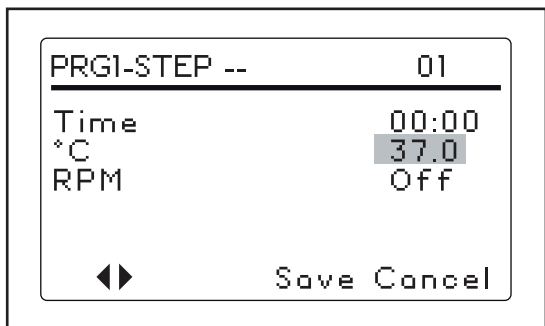

8. Press the **Control knob** to save the setting.
9. Turn the **Control knob** to highlight the °C value.
10. Press the **Control knob**.
The °C value flashes.

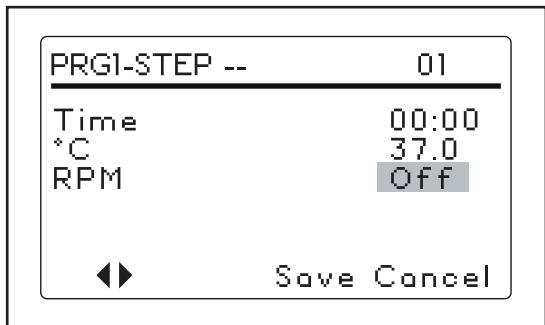

11. Set the temperature desired and press the **Control knob** to save your setting.
12. Turn the **Control knob** to highlight the *RPM* value (*Off* in the sample figure).
13. Press the **Control knob**.
The *RPM* value flashes.
14. Turn the **Control knob** to select a speed.

15. Press the **Control knob** to save your selection.

Operation

New Brunswick™ Innova® 40/40R Shaker
English (EN)

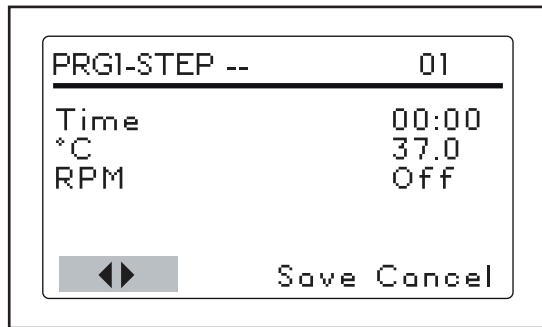

16. To program a second step, use the **Control knob** to highlight the double arrows in the bottom-left corner of the screen.

17. Press the **Control knob**.

The double arrows flash.

18. Turn the **Control knob** 1 click clockwise to go to the Step 2 screen.

19. Press the **Control knob** to start programming Step 2 like you did with Step 1. You can program up to 15 Steps.

5.11.2 Save the program

To save a program:

1. Highlight *Save* and press the *Control knob*.

Save flashes.

2. Press the **Control knob** again to save the program.

The LCD displays *Process Running — Saving Profile* for a few seconds and then return to the main *PROG* screen.

5.11.3 Edit a program

Use the *Edit* mode to open a program you have already created and saved, in order to modify your settings following the same procedures.

5.11.4 Run and stop a program

Use the *Run* mode to turn a specific program on. Only one program can run at a time. When you change the mode to *Run*, the screen shows the *Run* icon.

To stop a program, change the program mode to *Off*.

5.12 Program the timer

By setting an *HRS* setpoint in the *DISP* or *SUMM* screen, the shaker may be set to automatically stop after a preset time period of 0 hr 1 min – 99 hr 59 min.

If the time is set to *0:00*, the shaker operates continuously until either the lid is opened or the **Start/Stop switch** is pushed.

5.13 Power interruption

In the event of a mains/power failure, the Innova 40/40R Shaker is equipped with an automatic restart function. The shaker's non-volatile memory retains all stored information.

If the shaker was in operation prior to the power interruption, the shaker begins to operate at its last entered setpoints. The alarm *POWER* flashes on the display, indicating that a power interruption has occurred. Turn the **Control knob** in any direction to acknowledge the visual alarm. The flashing stops.

5.14 Remote programming

You can use a communications program (such as HyperTerminal®) to send commands to the shaker from your PC.



- HyperTerminal is not included with Windows® Vista or 7.

5.14.1 Connecting to a computer

Before setting up communication software, check the *Mode* and *Baud Rate* parameter settings found on the *RS232* screen of the shaker (see *RS-232 screen on p. 33*).

- ▶ Set the shaker's *Mode* parameter to *Slave*.
- ▶ Set the appropriate *Baud Rate*.

5.14.1.1 Setting up serial connection with HyperTerminal

1. Connect the RS-232 cable between the computer and the shaker's RS-232 port.
2. Start HyperTerminal and follow the steps for setting a new connection.
3. Select the COM port you will be using, then set the COM parameters to the following values:

Baud rate	Enter the setting on your shaker
Data bits	8
Parity	None
Stop bits	1
Flow control	None

5.14.1.2 Testing the connection

1. Turn the shaker off.
2. Start HyperTerminal.
3. Turn the shaker on.

If a connection is made, the shaker sends an *OK* to the communication software.

Operation

New Brunswick™ Innova® 40/40R Shaker
English (EN)

5.14.2 Sending commands

With the command program, the user send commands to the Innova 40/40R Shaker by computer.

- The serial interface uses an echo character protocol that is implemented to indicate that a valid character has been received by the shaker.
- For every character sent by the user computer, the Innova 40/40R Shaker returns a matching character.
- This echo character should be read by the computer and compared to the character that was sent.



- When sending a command in HyperTerminal, do not allow the pause between any two characters of you message to last longer than 10 s.
- After 10 s the shaker's serial port resets itself.

This is the command set format:

<Command><Space><Arg1><Space><Argn><CR>

- Most Commands are defined as 2 capital characters using the ASCII character set (see *Index to command codes on p. 45*).
- If a command has several arguments (Argn), the ASCII space control character separates each argument.
- The command is sent using the ASCII carriage return (CR) control character.
- The line feed control character may also be included but must follow the carriage return character.

When a command is sent that returns data, the characters returned are in ASCII format. Each additional argument returned is separated by the ASCII space or tab control character. Refer to the selected command for the actual format. Data returned is terminated with a carriage return line feed control character sequence.

5.14.2.1 Example: Commanding set speed

In the following example, the computer sets the shaker speed to 250 rpm:

- ▶ In HyperTerminal, type **CS<Space>250<CR>**.
The shaker echos **CS<Space>250<CR>**
The shaker is set to 250 rpm



Do not type the angled brackets. <Space> means press the space bar. <CR> means press the carriage return.

5.14.2.2 Example: Requesting measured values

▶ Type **RV**<CR>.

The shaker echos **RV**<CR>

The shaker reports:

- Arg1 (Speed rpm)
- Arg2 (Temperature °C)
- Arg3 (Humidity %)
- Arg4 (CO₂ %)
- Arg5 (Grow lamp 0 = Off, 1 = On)
- Arg6 (UV lamp 0 = Off, 1 = On)

These values are separated by <Tab>.

This looks like:

250 29 90 0 0 0

5.14.3 Set Commands

Code	Meaning	Command format	Return data
CS	Command speed	CS <Space><Arg1><CR>	• Arg1 = Speed setpoint
CT	Command temperature	CT <Space><Arg1><CR>	• Arg1 = Temperature setpoint

5.14.4 Program control commands

Code	Meaning	Command format	Return data
PC	Clear program (clears program steps)	PC <Space><Arg1><Space><Arg2><CR> Note: If Arg2 is not included, all 15 steps of selected program are cleared.	<ul style="list-style-type: none"> • Arg1 = Program number (1 – 4) • Arg2 = Step number (1 – 15)
PM	Program mode (returns status of current program run/hold mode)	PM <CR>	<ul style="list-style-type: none"> • Arg1 = Run/hold status (0 = end, 1 = run) • Arg2 = Program number (1 – 4) • Arg3 = Step number (1 – 15) <p>Note: If a program has not been selected to run, a 0 is returned for program number and step number</p>

Operation

New Brunswick™ Innova® 40/40R Shaker
English (EN)

Code	Meaning	Command format	Return data
PR	Read program step in memory	PR <Space><Arg1><Space><Arg2><CR>	<ul style="list-style-type: none"> • Arg1 = Profile number (1 – 4) • Arg2 = Step number (1 – 15) <p>Note: if ARG2 = * (asterik) all steps returned</p> <ul style="list-style-type: none"> • Arg9 = Grow lamp (0 = off, 1 = on) • Arg8 = UV lamp (0 = off, 1 = on) • Arg7 = Step minutes (0 – 59) • Arg6 = Step hours (0 – 99) • Arg5 = CO₂ setpoint % (future option, returns 0.0) • Arg4 = Speed setpoint rpm • Arg3 = Temperature setpoint °C
PS	Program stop/start (stops or starts a program)	PS <CR> With no other parameters, any program currently running is stopped. PS <Arg1><Space><Arg2><CR>	<ul style="list-style-type: none"> • Arg1 = Program number (1 – 4) • Arg2 = Step number (1 – 15) <p>Note: If Arg2 is not included, the program starts in Step 1.</p>

Code	Meaning	Command format	Return data
PW	Write Program step to memory	PW <Space><Arg1><Space>...<Arg7><CR>	<ul style="list-style-type: none"> • Arg1 = Program number (1 – 4) • Arg2 = Step number (1 – 15) • Arg3 = Temperature setpoint °C • Arg4 = Speed setpoint rpm • Arg5 = CO₂ setpoint % • Arg6 = Step (0 – 99) • Arg7 = Step min (0 – 59)

5.14.5 Report request commands

Code	Meaning	Command format	Return data
RI	Report software version	RI <CR>	<ul style="list-style-type: none"> • Arg1 = Display module software version • Arg2 = Control module software version
RP	Report parameter list (ASCII text header)	RP <CR>	<ul style="list-style-type: none"> • Arg1 = Speed rpm • Arg2 = Temperature °C • Arg3 = CO₂ %
RV	Report measured values	RV <CR>	<ul style="list-style-type: none"> • Arg1 = Speed rpm • Arg2 = Temperature °C • Arg3 = CO₂ %
RS	Report setpoint values	RS <CR>	

Operation

New Brunswick™ Innova® 40/40R Shaker
English (EN)

5.14.6 Set/Get date and time commands

Code	Meaning	Command format	Return data
=D	Set date and time	=D<Space><Arg1><Space><Arg2>...<Arg7><CR> <ul style="list-style-type: none"> • Arg1 = Hours (0 – 23) • Arg2 = Minutes (0 – 59) • Arg3 = Seconds (0 – 59) • Arg4 = Year (00 – 99) • Arg5 = Month (01 – 12) • Arg6 = Date (1 – 31) • Arg7 = Day (1 – 7) <ul style="list-style-type: none"> – 1 = Monday – 2 = Tuesday – 3 = Wednesday – 4 = Thursday – 5 = Friday – 6 = Saturday – 7 = Sunday 	
?D	Viewing date and time	?D<CR>	<ul style="list-style-type: none"> • Arg1 = Hours (0 – 23) • Arg2 = Minutes (0 – 59) • Arg3 = Seconds (0 – 59) • Arg4 = Year (00 – 99) • Arg5 = Month (01 – 12) • Arg6 = Date (1 – 31) • Arg7 = Day (1 – 7) <ul style="list-style-type: none"> – 1 = Monday – 2 = Tuesday – 3 = Wednesday – 4 = Thursday – 5 = Friday – 6 = Saturday – 7 = Sunday

For example, the following command:

5.14.6.1 Example: Viewing date and time

1. Type =?.

The shaker returns *03 30 00 13 07 04 07*

This means the shaker date and time is set to July 04, 2013 03:30:00 am.

5.14.6.2 Example: Programming date and time

To set the date to Wednesday March 26, 2013 01:30:12 am

▶ Type =D<Space>01<Space>30<Space>12<Space>13<Space><03><Space>26<Space>03<CR>

This looks like:

01 30 12 13 03 26 03

5.14.7 Index to command codes

Tab. 5-3: Command codes

Command Code	Meaning
CC	Command CO ₂
CH	Command Relative Humidity
CL	Command Grow Lamp
CS	Command Speed
CT	Command Temperature
CU	Command UV Lamp
PC	Clear Program
PM	Program Mode
PR	Read Program Step in memory
PS	Program Stop/Start
PW	Write Program Step to memory
RI	Report Software Version
RP	Report Parameter List
RS	Report Setpoint Values
RV	Report Measured Values
=D	Set Date and Time
?D	Get Date and Time

Operation

New Brunswick™ Innova® 40/40R Shaker
English (EN)

6 Troubleshooting

6.1 Troubleshooting

Symptom	Cause	Solution
Shaker does not run.	<ul style="list-style-type: none"> • Mains/power cord is not plugged in. 	<ul style="list-style-type: none"> ▶ Plug in mains/power cord to working mains/power outlet.
	<ul style="list-style-type: none"> • Lid is ajar. 	<ul style="list-style-type: none"> ▶ Ensure lid is closed firmly.
	<ul style="list-style-type: none"> • Defective main board. • On/Off switch is broken. • Defective display board. • Jammed shaking mechanism. • Defective motor. • Drive belt out of alignment or worn. 	<ul style="list-style-type: none"> ▶ Call for service.
	<ul style="list-style-type: none"> • Shaking speed has been set to 0 by program running or by computer interface. 	<ul style="list-style-type: none"> ▶ Reset shaking speed.
	<ul style="list-style-type: none"> • Improperly installed fuse. 	<ul style="list-style-type: none"> ▶ Remove and reinstall fuse.
Shaker runs slowly and/or there is no speed indication.	<ul style="list-style-type: none"> • Improperly installed fuse. 	<ul style="list-style-type: none"> ▶ Remove and reinstall fuse.
	<ul style="list-style-type: none"> • Incorrect speed calibration. 	<ul style="list-style-type: none"> ▶ Recalibrate shaking speed.
	<ul style="list-style-type: none"> • Defective main board. • Defective motor. • Drive belt out of alignment or worn. 	<ul style="list-style-type: none"> ▶ Call for service.
Shaker does not run at set speed.	<ul style="list-style-type: none"> • Shaker is running in Program mode. • Shaker speed has been changed by computer interface. 	<ul style="list-style-type: none"> ▶ Check Run icon. ▶ Check shaker speed.
	<ul style="list-style-type: none"> • Shaker is overloaded and/or you are using baffled flasks. 	<ul style="list-style-type: none"> ▶ Remove some contents and balance load.
	<ul style="list-style-type: none"> • Defective motor. • Drive belt out of alignment or worn. 	<ul style="list-style-type: none"> ▶ Call for service.
	<ul style="list-style-type: none"> • Speed not calibrated correctly. 	<ul style="list-style-type: none"> ▶ Check speed calibration.
	<ul style="list-style-type: none"> • Load out of balance. 	<ul style="list-style-type: none"> ▶ Unload all contents and reload.
Excessive operating noise.	<ul style="list-style-type: none"> • Loose components in platform, subplatform, and/or drive assembly. 	<ul style="list-style-type: none"> ▶ Call for service.

Troubleshooting

New Brunswick™ Innova® 40/40R Shaker
English (EN)

Symptom	Cause	Solution
Shaker does not reach set temperature.	<ul style="list-style-type: none"> • Shaker is running in Program mode. • Shaker speed has been changed by RS-232 command/ computer interface. 	<ul style="list-style-type: none"> ▶ Check Run icon. ▶ Check shaker speed.
	<ul style="list-style-type: none"> • Heater fuse blown. • Compressor fuse blown. 	▶ Replace fuse.
	<ul style="list-style-type: none"> • Compressor over-pressure switch activated. • Defective heater. • Defective refrigeration system. 	▶ Call for service.
	<ul style="list-style-type: none"> • Ambient temperature too high or too low. 	▶ Adjust the room temperature.
Incorrect temperature indication.	<ul style="list-style-type: none"> • Temperature Offset has been programmed. 	▶ Look for Offset icon in display.
	<ul style="list-style-type: none"> • Defective RTD assembly. • Defective main board. 	▶ Call for service.

7 Maintenance

7.1 Routine maintenance

No routine maintenance schedule is required for the Innova 40/40R Shaker.

Clean the shaker occasionally with a conventional household (non-abrasive) cleaner.

To ensure proper air flow in and around the shaker, vacuum or sweep the area around the shaker to remove dust and other debris.

7.2 Cleaning external and internal surfaces



WARNING! Personnel injury and equipment damage

- ▶ Always turn off the shaker and disconnect the mains/power cord from the mains/power supply before cleaning the shaker.



NOTICE! Risk of equipment damage

- ▶ Do not use abrasive or corrosive compounds to clean the shaker.
-

1. Routinely clean the exterior of the shaker by wiping it over with a soft cloth, moistened with soapy water.
Rinse the soap from the cloth in clean water, and wipe the exterior surfaces again.

If there is biohazard contamination, see below.

7.3 Biohazard decontamination



WARNING! Risk of potential harm to personnel

- ▶ It is the responsibility of the user to carry out appropriate decontamination procedures if hazardous material is spilled on or inside the equipment. Before using any cleaning or decontamination method other than those suggested by the manufacturer, users should contact Eppendorf that the proposed method would not damage the equipment.



CAUTION! Risk of potential harm to personnel

- ▶ As a routine precaution, wear protective gloves.
 - ▶ Be sure to adequately ventilate the work area as you disinfect, to avoid the formation of potentially explosive alcohol vapors.
-

Maintenance

New Brunswick™ Innova® 40/40R Shaker
English (EN)

Commercially available household bleach solutions, when diluted at a 1:10 ratio, are effective in routine decontamination of the instrument. The method for decontaminating a spill depends upon the nature of the spill.

1. Switch off the shaker. Unplug the shaker from the mains/power supply.
2. Spills involving fresh cultures or samples known to have low concentrations of biomass should be flooded with decontamination solution and soaked for 5 min before cleanup.
Spills involving samples with high concentrations of biomass, or involving organic matter, or occurring in areas warmer than room ambient temperature, should be exposed to decontamination solution for at least 1 h before cleanup.

8 Technical data

8.1 Specifications



Use of baffled flasks significantly reduces maximum speed for any shaker.

These specifications assume a maximum load of 15.5 kg (34 lb), including platforms, clamps, glassware and contents.

8.1.1 Shaking

Speed	25 rpm – 500 rpm
Control accuracy	±1 rpm
Stroke	1.9 cm (3/4 in) or 2.5 cm (1 in)
Indication	Displayed in 1 rpm increments
Alarm signal with speed deviation	±5 rpm
Drive mechanism	Triple-eccentric counterbalanced drive with 9 permanently lubricated ball bearings. Driven by a solid-state brushless motor
Heaters	Low watt-density, resistance heaters with high-temperature safety thermostat cut-out.

8.1.2 Temperature system

Innova 40 temperature range	5 °C above ambient temperature to 80 °C
Innova 40R temperature range	15 °C below ambient temperature (minimum 4 °C) to 80 °C
Control accuracy	±0.1 °C at 37 °C
Indication	Displayed in 0.1 °C increments
Alarm signal with temperature deviation	±1 °C
Altitude limit	2000 m

8.1.3 Power supply

Mains/power supply	100 V ±10 %, 50 – 60 Hz 120 V ±10 %, 60 Hz 230 V ±10 %, 50 Hz	40: 800 VA 40R: 1500 VA
--------------------	---	----------------------------

Technical data

New Brunswick™ Innova® 40/40R Shaker
English (EN)

8.1.4 Ambient conditions

Ambience	Only for use indoors.
Ambient temperature	10 °C – 35 °C
Relative humidity	20 % – 80 %, non-condensing

8.1.5 Dimensions and weight

Dimensions	Width: 55.9 cm (22 in) Depth: 76.2 cm (30 in) Height: 61 cm (24 in) Lid open height: 102 cm (40 in)
Chamber dimensions	Width: 51.4 cm (20.3 in) Depth: 54.4 cm (21.5 in) Height: 35.6 cm (14 in)
Platform dimensions	Width: 46 cm (18 in) Depth: 46 cm (18 in) (Select universal or dedicated styles.)
Space requirements	Width: 68.6 cm (27 in) Depth: 83.2 cm (33 in) Height: 106.7 cm (42 in)
Weight	Innova 40 net weight: 60 kg (133 lb) Innova 40R net weight: 79 kg (175 lb)

8.1.6 Alarms

There is a visible and audible warning indication when:

- Speed deviates more than ± 1 rpm from setpoints.
- Temperature deviates more than ± 1 °C from setpoints.
- When timer has expired.

Audible alarm can be muted.

8.1.7 Display

- 240 cm × 128 cm backlit LCD

8.1.8 RS-232

- Remote control.
- Remote monitoring.
- Remote data logging.

8.1.9 ETL regulatory standards

- UL 61010A-1
- UL 61010A-2-010
- CAN/CSA-C22.2 No. 1010.1
- CAN/CSA-C22.2 No. 1010.2.010

8.1.10 CE regulatory standards

For CE regulatory standards, see Declaration of Conformity on p. 63.

8.2 Certifications

The Innova 40/40R Shaker has been tested to ETL standards, to comply with UL and CAN/CSA electrical safety standards.

As attested in the CE Declaration of Conformity, the Innova 40/40R Shaker also conform to the appropriate CE standards.

Technical data

New Brunswick™ Innova® 40/40R Shaker
English (EN)

9 Ordering information

9.1 Replacement parts

We recommend that you have on hand:

Tab. 9-1: Spare parts kit M1352-6000

Description	Quantity
V-Belt	1
Gas springs	2
Fuse, 8 A	4

9.2 Accessories

When ordering accessories, you may be asked to provide the model number and serial number of your shaker. This information is on the electrical specification plate, located on the rear panel of the unit.

9.2.1 Platforms

Description	Capacity	Part No.
Universal platform	(Tab. on p. 56)	M1250-9902
125 mL Erlenmeyer flask dedicated platform ¹	34	M1194-9904
250 mL Erlenmeyer flask dedicated platform ¹	25	M1194-9905
500 mL Erlenmeyer flask dedicated platform ¹	16	M1194-9906
1 L Erlenmeyer flask dedicated platform ¹	9	M1194-9907
2 L Erlenmeyer flask dedicated platform ¹	5	M1194-9908
2.8 L Fernbach flask dedicated platform ¹	4	M1233-9932
Utility carrier with cushioned crossbars	–	M1194-9909
Utility tray with non-skid rubber surface	–	M1194-9910
Sticky Pad® platform	–	M1250-9903

Clamps for universal platform are sold separately.

Ordering information

New Brunswick™ Innova® 40/40R Shaker
English (EN)

Tab. 9-2: Universal platform flask capacities

Flask Type	Capacity	Part No.
10 mL	109	ACE-10S
25 mL	64	M1190-9004
50 mL Erlenmeyer flasks	45	M1190-9000
125 mL Erlenmeyer flasks	21	M1190-9001
250 mL Erlenmeyer flasks	18	M1190-9002
500 mL Erlenmeyer flasks	14	M1190-9003
1 L Erlenmeyer flasks	8	ACE-1000S
2 L Erlenmeyer flasks	5	ACE-2000S
2.8 L Fernbach flasks	4	ACSB-2800S
3 L Erlenmeyer flasks	4	ACE-3000S

9.2.2 Replacement clamp hardware kits

Eppendorf flask clamps come complete with mounting screws. Additional screws are available separately in packs of 25 (S2116-3051P).

9.2.3 Test tube racks and other accessories

Tab. 9-3: Racks and Trays

Accessory Description		Part Number	Platform Capacity
Adjustable angle test tube rack for tubes 8 mm – 11 mm diameter	80 tube capacity	M1289-0100	7
	60 tube capacity	M1289-0010	9
	48 tube capacity	M1289-0001	9
Adjustable angle test tube rack for tubes 12 mm – 15 mm diameter	60 tube capacity	M1289-0200	7
	44 tube capacity	M1289-0020	9
	34 tube capacity	M1289-0002	9
Adjustable angle test tube rack for tubes 15 mm – 18 mm diameter	42 tube capacity	M1289-0300	7
	31 tube capacity	M1289-0030	9
	24 tube capacity	M1289-0003	9
Adjustable angle test tube rack for tubes 18 mm – 21 mm diameter	30 tube capacity	M1289-0400	7
	23 tube capacity	M1289-0040	9
	18 tube capacity	M1289-0004	9
Adjustable angle test tube rack for tubes 22 mm – 26 mm diameter	22 tube capacity	M1289-0500	7
	16 tube capacity	M1289-0050	9
	13 tube capacity	M1289-0005	9

Adjustable angle test tube rack for tubes 26 mm – 30 mm diameter	20 tube capacity	M1289-0600	7
	16 tube capacity	M1289-0060	9
	12 tube capacity	M1289-0006	9
Microplate holder rack (stacked)	3 deep well or 9 standard	M1289-0700	16
Microplate holder rack (single layer)	5 deep well or standard	TTR-221	4
Angled test tube rack holder ¹ for user-supplied test tube racks that are 10 mm – 13 mm (4 in – 5 in) wide and up to 38 mm (15 in) long.		TTR-210	4
Angled test tube rack spacer bar ¹ for use with TTR-210 to accommodate test tubes racks that are less than 13 mm (5 in) wide.		TTR-215	NA

¹ Universal Platform Required

Ordering information

New Brunswick™ Innova® 40/40R Shaker
English (EN)

10 Transport, storage and disposal

10.1 Disposal

In case the product is to be disposed of, the relevant legal regulations are to be observed.

Information on the disposal of electrical and electronic devices in the European Community:

Within the European Community, the disposal of electrical devices is regulated by national regulations based on EU Directive 2012/19/EU pertaining to waste electrical and electronic equipment (WEEE).

According to these regulations, any devices supplied after August 13, 2005, in the business-to-business sphere, to which this product is assigned, may no longer be disposed of in municipal or domestic waste. To document this, they have been marked with the following identification:



Because disposal regulations may differ from one country to another within the EU, please contact your supplier if necessary.

In Germany, this is mandatory from March 23, 2006. From this date, the manufacturer has to offer a suitable method of return for all devices supplied after August 13, 2005. For all devices supplied before August 13, 2005, the last user is responsible for the correct disposal.

Index

New Brunswick™ Innova® 40/40R Shaker
English (EN)

Index**A**

Accessories.....	15, 55
Alarms	15, 15, 16, 17
Ambient humidity.....	19
Ambient temperature	19
ASCII	40

B

Baud rate	34, 39
Biohazard decontamination	49

C

Chamber temperature	51
Changing screens	27
Clamp	
Double girdle clamp.....	23
Clamp installation.....	22
Clamp screws	22
Cleaning	49
Command codes.....	45
Command format.....	40
Commanding set speed	40
Connecting to computer.....	39
Create a program.....	36

D

Danger level	7
CAUTION	7
DANGER.....	7
NOTICE	7
WARNING	7
Decontamination	49
Device overview	
Front view	13
Rear view	13

Display screen.....	28, 52
Disposal	59
Drip pan	16

F

Flask clamp installation	22
Flasks	15
Front panel.....	25

G

Getting the time	44
------------------------	----

H

Heater	16
HyperTerminal	39, 39

I

Icons	
Alarm on	26
Lid open.....	26, 26
Lock on	26
Program running	26

L

LCD	52
Lid	
Opening the lid.....	28
Location	19

M

Mains/power	
Connecting to the mains/power supply.....	24
Manual conventions.....	8
Memory	
Non-volatile memory.....	39

O

Operating controls	25
--------------------------	----

Orbit 14	Sending commands 40
P	Set commands 41
Package list..... 14	Setpoints
Parameters 29	Changing setpoints..... 30
Parameter meanings 27	Viewing setpoints 29
Parameter names 27	Setting the time 44
Platform	Setting up serial connection 39
Installation 20	Setup screen 31
Platforms 15	Shaking speed..... 51
Power interruption 39	Software 16
Powering on shaker..... 25	Space requirements 19
Program	Speed 51
Create a program 36	Spill containment..... 16
Program control commands 41	Symbols used 8
Program timer 38	T
Programming from PC 39	Temperature 51
R	Testing serial connection..... 39
Refrigeration 14	Timed run 38
Remote alarm 17	Timer
Remote programming 39	Programming the timer 39
Report request commands 43	Tubes 15
Requesting measured values..... 41	U
Routine maintenance 49	User requirement..... 11
RS-232 14, 16, 19, 33, 39	Using this manual 7
RS-232 mode 34	
RS-232 screen 33	
RTD..... 16, 48	
S	
Screen operation 27	
Screens	
Description..... 27	
Meaning 27	
Selecting the location 19	

Index

New Brunswick™ Innova® 40/40R Shaker
English (EN)

Declaration of Conformity

The product named below fulfills the requirements of directives and standards listed. In the case of unauthorized modifications to the product or an unintended use this declaration becomes invalid.

Product name:

Innova® 40 / Innova® 40R
including accessories

Product type:

Laboratory Shaker

Relevant directives / standards:

2006/95/EC: EN 61010-1, EN 61010-2-010
2004/108/EC: EN 61326-1, EN 61000-3-2, EN 61000-3-3
2011/65/EU
2012/19/EU



Management Board



Portfolio Management

Date: September 30, 2013

Your local distributor: www.eppendorf.com/contact
Eppendorf AG · 22331 Hamburg · Germany
eppendorf@eppendorf.com

Eppendorf and the Eppendorf Logo are registered trademarks of Eppendorf AG Hamburg/Germany.
All rights reserved incl. graphics and pictures. Copyright 2013 © by Eppendorf AG.

ISO 9001
Certified

ISO 13485
Certified

ISO 14001
Certified

Evaluate Your Manual

Give us your feedback.
www.eppendorf.com/manualfeedback